Midwest Sewer Services

P.O. Box 10853 White Bear Lake, MN 55110
651-492-7550/Brian@Midwestsoiltesting.com

Brian Humpal
MPCA Licensed Advanced Inspector

SUBSURFACE SEWAGE TREATMENT SYSTEM (SSTS) COMPLIANCE REPORT

Date: 9/11/23 & 9/18/23

Time: 12:45 PM

Owner: Bjorn Anderson

Inspection Address: 9426 Lansing Ave N, Grant, MN 55082

REPORT SUMMARY

I have performed an “MPCA Compliance Inspection” on this system and have reviewed the original design/permit records on file at Washington County. This system (installed in 2016) consists of two pre-cast septic tanks, a pre-cast lift tank, and a mound. Smilie’s Sewer Service pumped the tanks on September 11, 2023

Predicated on my inspection of the system and my review of the original design/permit records, it is my opinion that this system presently meets MPCA minimum compliance inspection requirements.

Midwest Sewer Services have been hired to perform a compliance inspection of this SSTS for compliance with local ordinances pursuant to Minn. Stat. § 115.55 (2013). This compliance inspection covers only the criteria required by Minn. Stat. § 115.55 Subd. 5a (2013) and Minn. R. 7080.1500 (2011). A compliance inspection is an indication of the current compliance status of the system and does not guarantee the performance or longevity of this system beyond the date of inspection, as it is impossible to determine the future performance of any system. Midwest Sewer Services disclaim any use of this compliance inspection beyond determining SSTS compliance pursuant to Minn. Stat. § 115.55 Subd. 5a (2013) and Minn. R. 7080.1500 (2011).

Please contact me should you have any questions.



Christopher Uebe

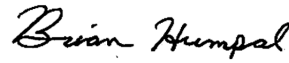

Brian Humpal

Compliance inspection report form

Existing Subsurface Sewage Treatment System (SSTS)

Doc Type: Compliance and Enforcement

Instructions: Inspector must submit completed form to Local Governmental Unit (LGU) and system owner within 15 days of final determination of compliance or noncompliance. Instructions for filling out this form are located on the Minnesota Pollution Control Agency (MPCA) website at <https://www.pca.state.mn.us/sites/default/files/wq-wwists4-31a.pdf>.

Property information

Local tracking number: _____

Parcel ID# or Sec/Twp/Range: _____ Reason for Inspection _____ Property Transfer _____

Local regulatory authority info: Washington CountyProperty address: 9426 Lansing Ave N, Grant, MN 55082Owner/representative: Bjorn Anderson Owner's phone: 651-353-3097Brief system description: Two pre-cast septic tanks, a pre-cast lift tank, and a mound.

System status

System status on date (mm/dd/yyyy): 9/18/2023
 Compliant – Certificate of compliance*

(Valid for 3 years from report date unless evidence of an imminent threat to public health or safety requiring removal and abatement under section 145A.04, subdivision 8 is discovered or a shorter time frame exists in Local Ordinance.)

***Note: Compliance indicates conformance with Minn. R. 7080.1500 as of system status date above and does not guarantee future performance.**

 Noncompliant – Notice of noncompliance

Systems failing to protect ground water must be upgraded, replaced, or use discontinued within the time required by local ordinance.

An imminent threat to public health and safety (ITPHS) must be upgraded, replaced, or its use discontinued within ten months of receipt of this notice or within a shorter period if required by local ordinance or under section 145A.04 subdivision 8.

Reason(s) for noncompliance (check all applicable)

- Impact on public health (Compliance component #1) – *Imminent threat to public health and safety*
- Tank integrity (Compliance component #2) – *Failing to protect groundwater*
- Other Compliance Conditions (Compliance component #3) – *Imminent threat to public health and safety*
- Other Compliance Conditions (Compliance component #3) – *Failing to protect groundwater*
- System not abandoned according to Minn. R. 7080.2500 (Compliance component #3) – *Failing to protect groundwater*
- Soil separation (Compliance component #5) – *Failing to protect groundwater*
- Operating permit/monitoring plan requirements (Compliance component #4) – *Noncompliant - local ordinance applies*

Comments or recommendations

Certification

I hereby certify that all the necessary information has been gathered to determine the compliance status of this system. No determination of future system performance has been nor can be made due to unknown conditions during system construction, possible abuse of the system, inadequate maintenance, or future water usage.

By typing my name below, I certify the above statements to be true and correct, to the best of my knowledge, and that this information can be used for the purpose of processing this form.

Business name: Midwest Sewer Services Certification number: 5342/9852Inspector signature:  License number: L2896
(This document has been electronically signed) Phone: 651-492-7550

Necessary or locally required supporting documentation (must be attached)

- Soil observation logs System/As-Built Locally required forms Tank Integrity Assessment Operating Permit
- Other information (list): Report Summary, Property Information, Disclaimer

Property Address: 9426 Lansing Ave N, Grant, MN 55082

Business Name: Midwest Sewer Services

Date: 9/18/2023

1. Impact on public health – Compliance component #1 of 5**Compliance criteria:**

System discharges sewage to the ground surface	<input type="checkbox"/> Yes* <input checked="" type="checkbox"/> No
System discharges sewage to drain tile or surface waters.	<input type="checkbox"/> Yes* <input checked="" type="checkbox"/> No
System causes sewage backup into dwelling or establishment.	<input type="checkbox"/> Yes* <input checked="" type="checkbox"/> No

Any "yes" answer above indicates the system is an imminent threat to public health and safety.

Describe verification methods and results:

None of the above found.

Attached supporting documentation: Other: _____ Not applicable**2. Tank integrity – Compliance component #2 of 5****Compliance criteria:**

System consists of a seepage pit, cesspool, drywell, leaching pit, or other pit?	<input type="checkbox"/> Yes* <input checked="" type="checkbox"/> No
Sewage tank(s) leak below their designed operating depth?	<input type="checkbox"/> Yes* <input checked="" type="checkbox"/> No
If yes, which sewage tank(s) leaks:	

Any "yes" answer above indicates the system is failing to protect groundwater.

Describe verification methods and results:**Attached supporting documentation:** Empty tank(s) viewed by inspectorName of maintenance business: Smilie's Sewer ServiceLicense number of maintenance business: L2428Date of maintenance: 9/11/2023 Existing tank integrity assessment (Attach)

Date of maintenance (mm/dd/yyyy): _____ (must be within three years)

(See form instructions to ensure assessment complies with Minn. R. 7082.0700 subp. 4 B (1))

 Tank is Noncompliant (pumping not necessary – explain below) Other: _____

Property Address: 9426 Lansing Ave N, Grant, MN 55082

Business Name: Midwest Sewer Services

Date: 9/18/2023

3. Other compliance conditions – Compliance component #3 of 5

3a. Maintenance hole covers appear to be structurally unsound (damaged, cracked, etc.), or unsecured?

Yes* No Unknown

3b. Other issues (*electrical hazards, etc.*) to immediately and adversely impact public health or safety? Yes* No Unknown

***Yes to 3a or 3b - System is an imminent threat to public health and safety.**

3c. System is non-protective of ground water for other conditions as determined by inspector? Yes* No

3d. System not abandoned in accordance with Minn. R. 7080.2500? Yes* No

***Yes to 3c or 3d - System is failing to protect groundwater.**

Describe verification methods and results:

Attached supporting documentation: Not applicable

4. Operating permit and nitrogen BMP* – Compliance component #4 of 5 Not applicable

Is the system operated under an Operating Permit? Yes No **If “yes”, A below is required**

Is the system required to employ a Nitrogen BMP specified in the system design? Yes No **If “yes”, B below is required**

BMP = Best Management Practice(s) specified in the system design

If the answer to both questions is “no”, this section does not need to be completed.

Compliance criteria:

a. Have the operating permit requirements been met? Yes No

b. Is the required nitrogen BMP in place and properly functioning? Yes No

Any “no” answer indicates noncompliance.

Describe verification methods and results:

Attached supporting documentation: Operating permit (Attach)

Property Address: 9426 Lansing Ave N, Grant, MN 55082

Business Name: Midwest Sewer Services

Date: 9/18/2023

5. Soil separation – Compliance component #5 of 5

Date of installation 2016 Unknown
(mm/dd/yyyy)

Shoreland/Wellhead protection/Food beverage lodging? Yes No

Compliance criteria (select one):

5a. For systems built prior to April 1, 1996, and not located in Shoreland or Wellhead Protection Area or not serving a food, beverage or lodging establishment: Yes No*
 Drainfield has at least a two-foot vertical separation distance from periodically saturated soil or bedrock.

5b. Non-performance systems built April 1, 1996, or later or for non-performance systems located in Shoreland or Wellhead Protection Areas or serving a food, beverage, or lodging establishment: Yes No*
 Drainfield has a three-foot vertical separation distance from periodically saturated soil or bedrock.*

5c. "Experimental", "Other", or "Performance" systems built under pre-2008 Rules; Type IV or V systems built under 2008 Rules 7080.2350 or 7080.2400 (Intermediate Inspector License required ≤ 2,500 gallons per day; Advanced Inspector License required > 2,500 gallons per day) Yes No*
 Drainfield meets the designed vertical separation distance from periodically saturated soil or bedrock.

Attached supporting documentation:

- Soil observation logs completed for the report
- Two previous verifications of required vertical separation
- Not applicable (No soil treatment area)
- Reviewed design and permit records.

Indicate depths or elevations

A. Bottom of distribution media	See Attached Boring Log(s)
B. Periodically saturated soil/bedrock	
C. System separation	
D. Required compliance separation*	

*May be reduced up to 15 percent if allowed by Local Ordinance.

***Any "no" answer above indicates the system is failing to protect groundwater.**

Describe verification methods and results:

Upgrade requirements: (Minn. Stat. § 115.55) An imminent threat to public health and safety (ITPHS) must be upgraded, replaced, or its use discontinued within ten months of receipt of this notice or within a shorter period if required by local ordinance. If the system is failing to protect ground water, the system must be upgraded, replaced, or its use discontinued within the time required by local ordinance. If an existing system is not failing as defined in law, and has at least two feet of design soil separation, then the system need not be upgraded, repaired, replaced, or its use discontinued, notwithstanding any local ordinance that is more strict. This provision does not apply to systems in shoreland areas, Wellhead Protection Areas, or those used in connection with food, beverage, and lodging establishments as defined in law.

8 of 11
Midwest Sewer Testing

Subsurface Sewage Treatment System Owner/Property Information

This information will be used for the purpose of conducting an MPCA Compliance Inspection.

Date of Inspection: 9/11/2023 & 9/18/2023		Time: 12:45 PM	
Property Address: 9426 Lansing Ave N, Grant, MN		Zip: 55082	
Property Owner: Bjorn Anderson		Phone: 651-353-3097	
Tank(s) <input checked="" type="checkbox"/> Septic 2 <input type="checkbox"/> Aerobic <input checked="" type="checkbox"/> Lift <input type="checkbox"/> Holding <input type="checkbox"/> Other: _____	Tank(s)Material <input type="checkbox"/> Fiberglass <input type="checkbox"/> Plastic <input type="checkbox"/> Metal <input checked="" type="checkbox"/> Concrete <input type="checkbox"/> Block <input type="checkbox"/> Other _____	Soil Treatment System <input type="checkbox"/> Rock trench <input type="checkbox"/> Gravelless trench <input type="checkbox"/> Chamber trench <input type="checkbox"/> Seepage bed <input checked="" type="checkbox"/> Mound <input type="checkbox"/> At-grade _____	Other <input type="checkbox"/> Alternative system _____ <input type="checkbox"/> Experimental system _____ <input type="checkbox"/> Cesspool system _____ <input type="checkbox"/> Other system _____
Are the tank maintenance covers accessible? <input checked="" type="checkbox"/> Yes <input type="checkbox"/> No *If no, proper maintenance must be performed through the maintenance holes. Maintenance hole covers should be made accessible to the ground surface to facilitate access and proper maintenance of the system.			
Year house built: 1965	Year septic installed: 2016	Tank size (gals.): 1-1500, 1-1000	
How long has seller owned the property?		Number of residents in home?	
Number of bedrooms? 4	Are all floors drained by gravity? Y		
Garbage disposal?	Whirlpool bath?		
More than one system (laundry, etc.)?			
Does this property have any footing drain tiles connected to the septic system?			
Are any buildings on this property such as garages or out-buildings connected to this system?			
Are there any additional systems on this property serving other buildings?			
Location of septic system on lot? Southwest Side			
Location of water well on lot? East Side		Is the well a deep well? Y	
Have you ever experienced any problems with the system such as: tree roots, sewage back-ups, surfacing of sewage onto the ground, septic tank overflowing, etc.; or have any repairs been made to the system? If yes, explain:			
When was the system last pumped? 9/11/2023		Name of pumper: Smilie's Sewer Service	
How often pumped in previous years?		Is system on a monitoring plan?	
Have you received notices from any government agency concerning this system?			
Is your property located in a shoreland management area? N			
Do you have any additional information that should be given to the new owner?			

I hereby certify that the above information is correct to the best of my knowledge. I also understand that if the system is considered "non-compliant/failing" per MPCA rules, that the inspector must by law submit a copy of this report to the local government unit within 15 days of the date of inspection completion. I also agree that unless otherwise noted in this report, that I/we are ultimately responsible for payment of all fees for all work performed relative to this inspection by Inspect Minnesota and Midwest Soil Testing

Owner/Occupant: _____

Date: _____

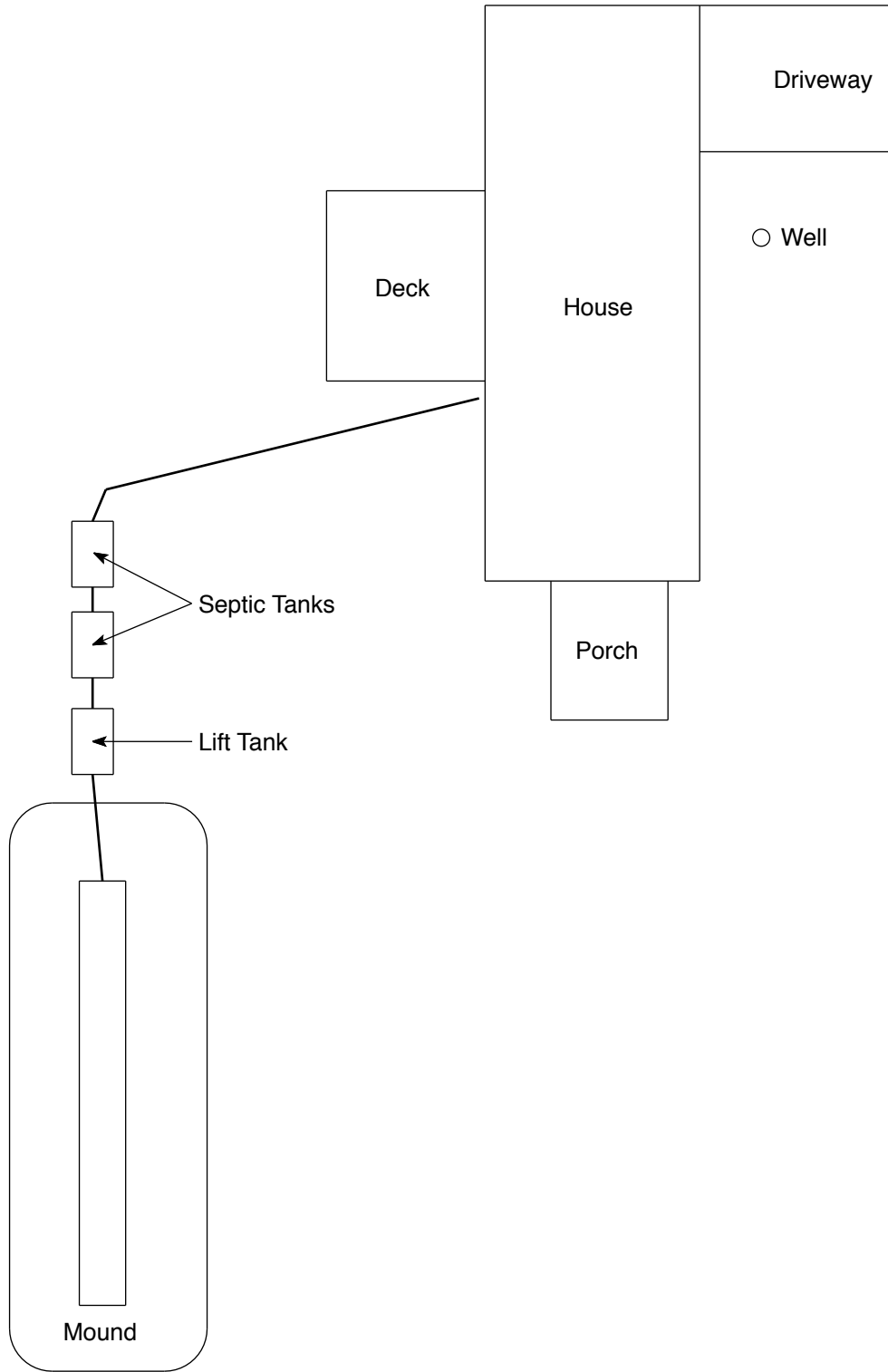

NO SCALE

9426 Lansing Ave N, Grant, MN 55082



Installation Permits Installation Permit Site Review UID # 5557

Installation Permit: Permit # 2016-0316

Status: Review Complete

Washington County Public Health & Environment

14949 - 62ND ST N, PO BOX 6,

STILLWATER, MN

55082-0006

(651) 430-6655

FAX (651) 430-6730

Site Inspection

Date of the soil observation:	10/11/16
Inspector:	Alex Pepin
Soil Information narrative:	in woods on foot of slope just outside of proposed rockbed downgrade
GPS Latitude :	45.085338 Latitude
GPS Longitude:	-92.879786 Longitude
Soil Parent Material Select all that apply:	<u>Till</u> <u>Outwash</u>
Landscape Position Please choose one:	<u>Foot Slope</u>
Vegetation:	wooded
Soil Survey Map Unit(s) with description:	504C  Duluth silt loam, 6 to 12 percent slopes

Soil Horizon Level 1

Depth:	0-12 Inches
Texture:	<u>sandy loam</u>
Matrix Color:	10 YR 3/2
Structure/Shape:	<u>Blocky</u>
Structure/Grade:	<u>Moderate</u>
Structure/Consistence:	<u>Friable</u>
Is this the Restrictive Layer?	<u>No</u>

Depth:	12-24 Inches
Texture:	<u>sandy loam</u>
Matrix Color:	10 YR 5/2
Redox Kind(s):	<u>Concentrations</u> <u>Depletions</u>
:	10 YR 4/6 concentrations and depleted matrix
Structure/Shape:	<u>Blocky</u>
Structure/Grade:	<u>Moderate</u>
Structure/Consistence:	<u>Firm</u>
Is this the Restrictive Layer?	<u>Yes</u>

Restrictive Layer Depth

Depth to Restriction:	12 Inches
-----------------------	-----------

Approvals

Approval	Signature
#1 Site Review Performed	Alex Pepin - 10/11/2016 4:02 PM 32cb387e0c38acc4f7c65837c8155d4b e5ea0c86639d27a5cd2d53a8497cf138

Public Notes

Text:	
File(s):

Internal Notes

Text:	
File(s):

SOIL BORING LOG

MAC'S SEWER SERVICE: By Michael D. McElhatton-Designer

Name: MATT-RIC PROPERTY

Date: 04/29/2016

Location: 9426 Lansing Ave., City of Grant, MN

USDA-SCS; Recovered by hand auger

Depth Inches	SOIL BORING # 1 Surface Elevation: 104'	Depth Inches	SOIL BORING # 2 Surface Elevation: 101' 2"
0-16	10yr 3/3 dark brown sandy loam	0-4	10yr 3/2 dark brown sandy loam
16-32	10yr 4/3 dark brown sandy loam	4-18	10yr 4/4 dark brown clay loam & gravel
	MOTTLING 26"+ Slight gravel		MOTTLING 18"+ Slight gravel
End of Boring at <u>2</u> ft.		End of Boring at <u>1.5</u> ft.	
Standing Water at Not present in hole <u>X</u> .		Standing Water at Not present in hole <u>X</u> .	
Mottled soil at <u>.6</u> ft Not present in hole _____.		Mottled soil at <u>1.5</u> ft Not present in hole _____.	
Comments: _____.		Comments: _____.	
Depth Inches	SOIL BORING # 3 Surface Elevation : no elev.	Depth Inches	SOIL BORING # 4 Surface Elevation : 102'
0-8	10yr 3/2 dark brown sandy loam	0-14	10yr 3/2 dark brown sandy loam
8-18	10yr 3/3 dark brown sandy loam	14-24	10yr 4/3 dark brown sandy loam
	MOTTLING 12"+ Slight gravel		MOTTLING 26"+ Slight gravel
End of Boring at <u>1.5</u> ft.		End of Boring at <u>2</u> ft.	
Standing Water at Not present in hole <u>X</u> .		Standing Water at Not present in hole <u>X</u> .	
Mottled soil at <u>1</u> ft Not present in hole _____.		Mottled soil at <u>2.2</u> ft Not present in hole _____.	
Comments: _____.		Comments: _____.	

DISCLAIMER

Brian L. Humpal, Inc. dba. Midwest Sewer Services, Inspect Minnesota, Midwest Soil Testing Relative to Subsurface Sewage Treatment System (SSTS) Compliance Inspections

1. This inspection/report is being performed for only the seller/owner of the property on which the SSTS is located. In such case that another party is paying for the inspection, the contract is between only said party and Brian L. Humpal, Inc.; there is no contract between Brian L. Humpal, Inc. and any other party unless otherwise noted.
3. Brian L. Humpal, Inc. has not been retained to warranty, guarantee, or certify the proper functioning of the SSTS for any period of time beyond the date of inspection or into the future. Because of the numerous factors (usage, maintenance, soil characteristics, previous failures, etc.) which may affect the proper operation of an SSTS, as well as the inability of Brian L. Humpal, Inc. to supervise or monitor the use or maintenance of the SSTS, the report shall not be construed as a warranty by Brian L. Humpal, Inc. that the SSTS will function properly for any particular party for any period of time.
4. Brian L. Humpal, Inc. is unable to verify the frequency and/or, quality of prior or future maintenance of the SSTS. Maintenance of the tank(s) must be performed through the tanks maintenance hole. The removal of solids from any location other than the maintenance hole is not a compliant method of maintenance. It is strongly recommended that maintenance covers be made accessible to the ground surface to facilitate proper maintenance.
5. Minimum Compliance Inspection requirements relative to this inspection and this report include only verification that the SSTS has tank(s) (septic tanks, lift tanks, dosing tanks, stilling tanks, etc.) which are watertight below the designed operating depth, the required separation between the bottom of the subsurface soil distribution medium and seasonally saturated soils, no back-ups of sewage into the dwelling, no discharge of sewage/effluent to the ground surface or surface waters, and no imminent safety hazards. Brian L. Humpal, Inc. does not inspect plumbing or pumps prior to the first SSTS component as these are plumbing components. The performance of exterior pumps and associated components are not inspected as they are considered to be maintenance items. Additionally, no indications relative to compliance with electrical code requirements have been made. It is recommended that any other applicable plumbing, electrical, housing, etc. inspections be performed by a qualified inspection business. Sewage back-up verification is limited to observing the floor drain area and/or the information supplied by the last occupants of the building prior to inspection. Brian L. Humpal, Inc. cannot guarantee that the information given to them by the last occupants of the building prior to inspection relative to back-ups is accurate.
4. Certification of this SSTS does not warranty future use beyond the date of the inspection. Any SSTS, old or new, can become hydraulically overloaded or discharge sewage/effluent to the ground surface as a result of more people moving into the house than were previously occupying the house, improper maintenance, heavy usage, leaking plumbing fixtures, groundwater infiltration, tree roots, freezing conditions, surface drainage problems, poor initial design, poor construction practices, or unsuitable materials used in constructing the system; the system can also simply stop working because of its age. An SSTS that has been properly designed and installed, properly maintained, and used in the manner for which the system was designed can be expected to provide service for twenty to twenty-five years on average. Some parts of the SSTS such as alarms, switches, pumps, filters, etc. will most likely have to be repaired or replaced over the lifetime of the system.
5. A Compliance Inspection is not meant to be a test or inspection for longevity of the system; a Compliance Inspection is strictly for the purpose of determining if the SSTS is protective of public health and safety, as well as the groundwater at the date and time the inspection was performed. This inspection is not intended to determine if the SSTS was originally designed or installed to past or present MPCA or other Local Government Unit code requirements. This inspection is not intended to determine if the SSTS was designed and/or installed to support the anticipated flow from the building as the use of the building may have changed since the design and construction of the SSTS due to the addition of bedrooms, occupants, etc. In addition, this inspection is not intended to determine the quality of the original SSTS design, the quality of the construction practices used while installing the SSTS, or the quality of the materials used in constructing the SSTS.
6. Brian L. Humpal, Inc. cannot guarantee the performance of SSTS products/components such as: gravelless pipe, chamber trenches, effluent filters, tanks, sewage pre-treatment components, piping, etc. Products such as gravelless pipe are no longer approved for installation in the State of Minnesota and may have a significantly reduced performance and/or life expectancy.
7. WINTER WORK: By accepting this report, it is understood that inspections conducted during winter months (approximately November 1st through April 1st) are more difficult to perform because of possible snow cover and/or ground frost. SSTS components such as tanks, maintenance covers, tank inspection pipes, subsurface distribution medium inspection pipes, and soil treatment areas are more difficult or impossible to locate due to snow cover and/or ground frost. In addition, soil borings are more difficult to perform due to snow cover and/or ground frost. Brian L. Humpal, Inc. will attempt to use the same level of standards when performing work during winter periods as when performing work during non-winter periods. However, the recipient of this report understands that because of the aforementioned considerations, the same level of standards may not be possible.
8. By accepting this report, the client understands that Brian L. Humpal, Inc. will not be responsible for any monetary damages exceeding the fee for the services provided.